

**Industrial Field:** Power Supply and Surface Treatment Equipment

**Business Field:** Research, Development, Experimentation, Maintenance

## DC Large Current and Power Conversion Efficiency Measurement of Plating System Power Supplies

DC 12000 A (Maximum) High Current Measurement with High Accuracy

### ■Background

Surface treatment (plating) equipment for parts used in transportation equipment (e.g. automobiles and railroads) and industrial application equipment (e.g. electronic components) requires high-performance DC power supplies with an output capacity of several thousand amperes. Accurately measuring the input/output characteristics of a power supply is very important for the development and maintenance of a high-performance DC power supplies that have the features of low ripple DC output, high efficiency, light weight, quietness, and long life. Generally speaking, the amount of plating film deposited onto a component is proportional to the applied current. In other words, since the plating film thickness is controlled by the amount of the applied current, it is necessary to know, with high-accuracy measurement, just how much current is being applied.

### ■Recommended Measurement System Example

The following current sensor configuration is ideal for measuring current of a plating equipment system as the one illustrated:

- 3 clamp type current sensors (CT6846-05) on the input primary side of the power supply
- 12 pass-through type current sensors (CT6877) on the output secondary side
- 3 sensor units (CT9557) that can each add up to 4 sensor outputs

By inputting the current from the sensors and the voltage to the power analyzer PW6001-06, the added current value and input/output conversion efficiency can be obtained.

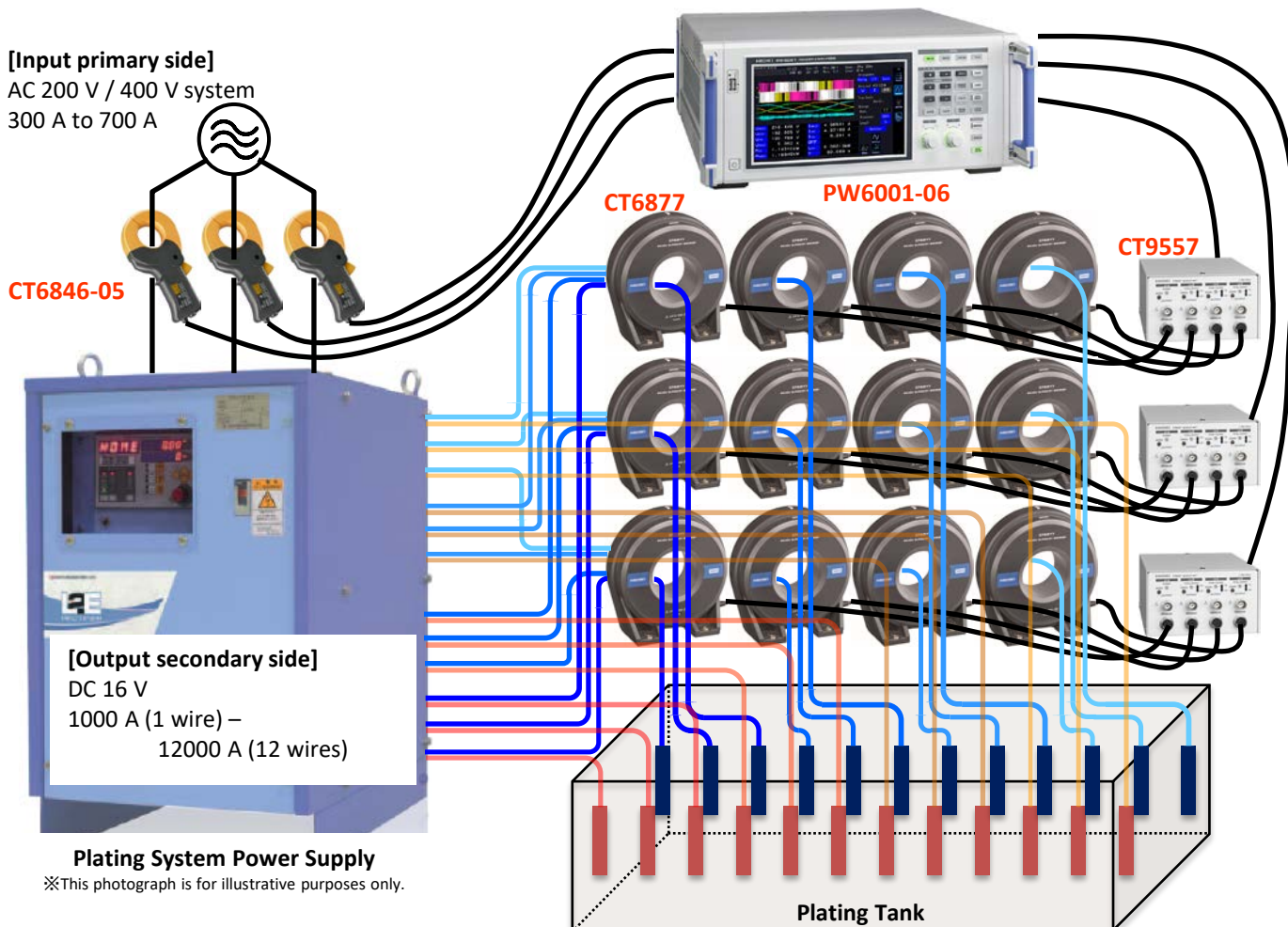

### Used Equipment

- Power Analyzer: PW6001-06 × 1 unit
- AC/DC Current Sensor: CT6846-05 (rated 1000 A, AC accuracy  $\pm 0.3\%$  rdg.  $\pm 0.01\%$  f.s.) × 3 units
- AC/DC Current Sensor: CT6877 (rated 2000 A, DC accuracy  $\pm 0.04\%$  rdg.  $\pm 0.008\%$  f.s.) × 12 units
- Sensor Units: CT9557 (aggregate output in 4ch multi-cable circuits) × 3 units

This information is valid as of June 2020 and specifications are subject to revision.

# HIOKI

## Introduction of Active Line Battery Analyzer

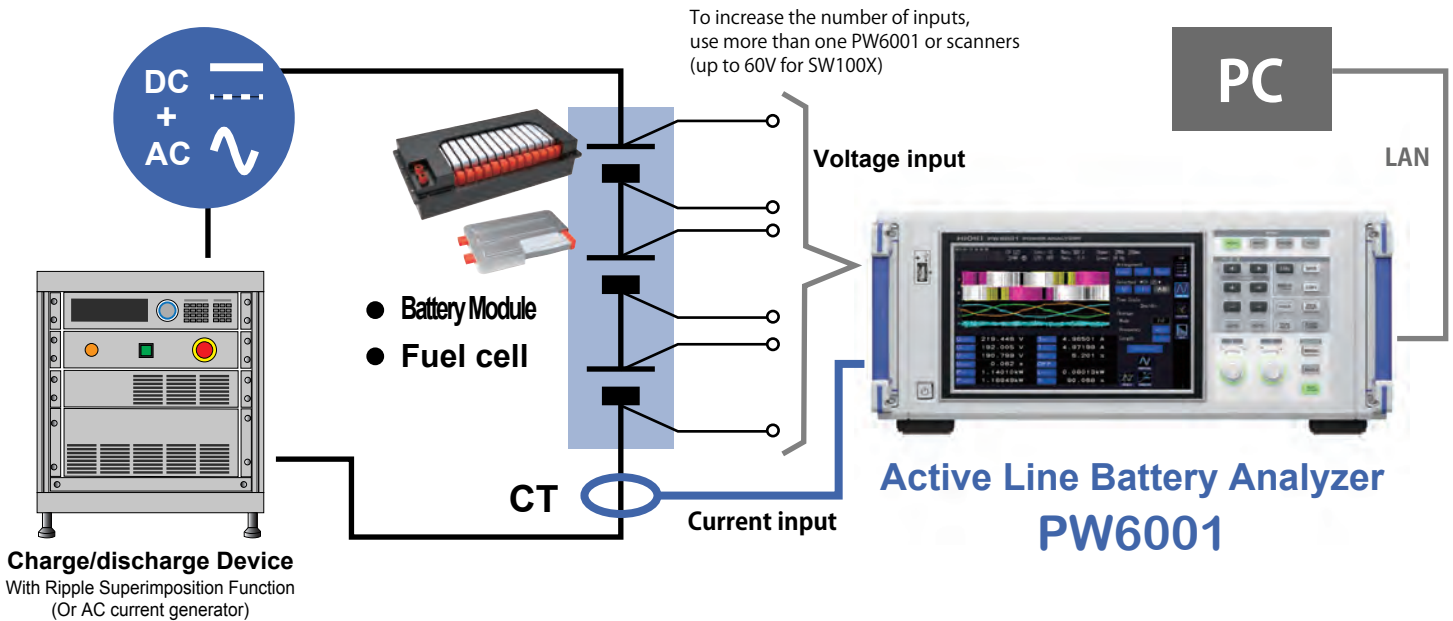

## Accurate impedance measurement during the charge/discharge test.

### Cole-Cole plot tests for LIB modules during charge/discharging

Using the Ripple Superimposition Function of a charge/discharge device and the calculation function of the analyzer, a Cole-Cole plot test of the entire cell and module can be performed for an active Li-ion battery module or fuel cell stack.

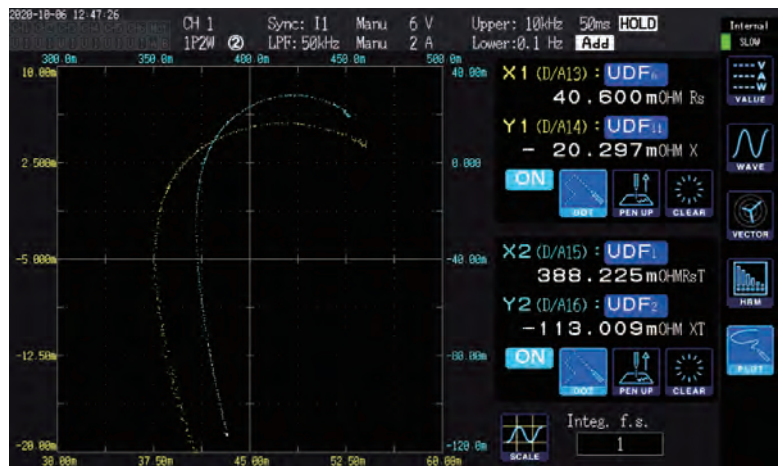

Cole-Cole plot diagram of an LIB unit cell and modules as a whole (frequency sweep up to 10kHz)

### Active Line Battery Analyzer Astounding Specs

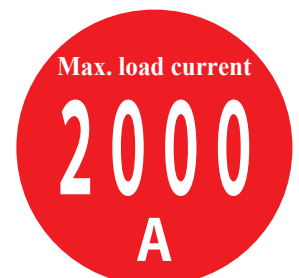
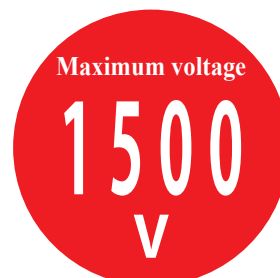

We plan to correspond to the 0.01Hz.

# Accurately calculate Rs-X-Z

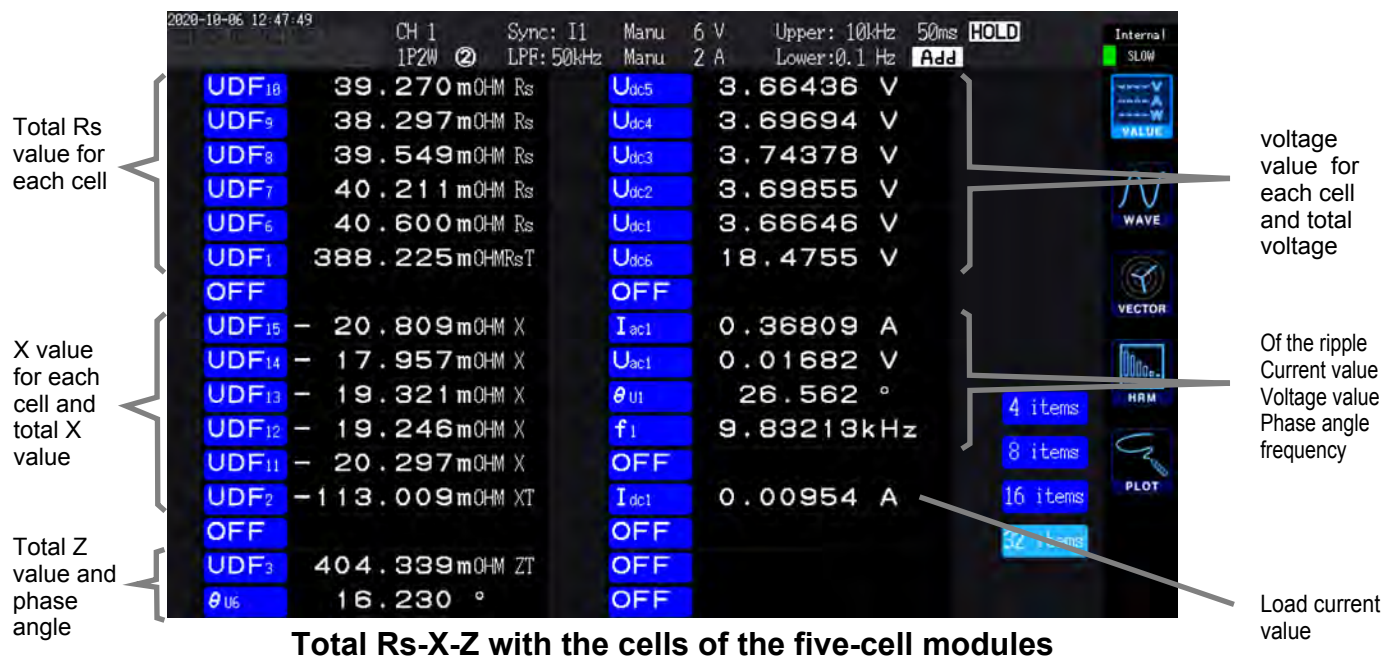

## Realize stable measurement by separating noise

The analyzer function provides PLL synchronization without being affected by noise, enabling stable impedance-measurement.



Discharge current and voltage waveform with noise



Cole-Cole plot diagram swept up to 10kHz during discharging

## Impedance measurement with the Memory HiCoder

Both the Memory HiCoder and Memory HiLogger can measure internal impedance because of their waveform and numerical calculation functions.

\* Either methods of DCIR or ACIR can be used. When using the DCIR method, please prepare an electronic load. When using the ACIR method, please prepare an AC current source.

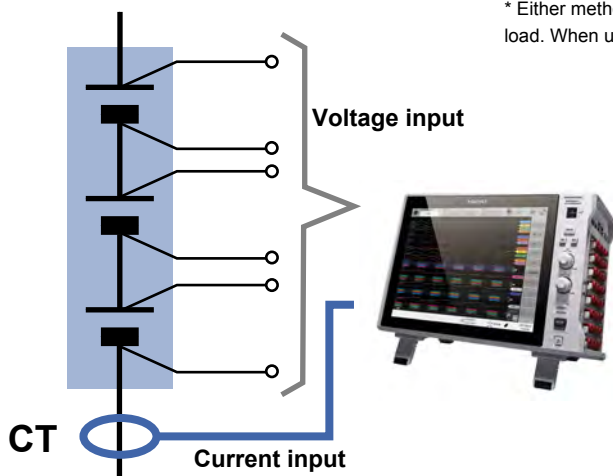

MR6000 Measured values



LR8450 Measured values

Electric Vehicles/ Energy R&D, Testing

## Loss Analysis of Reactors While in Operation

Power analyzer measures reactor Total loss and Core loss

### Why Should Reactor Loss be Analyzed?

By directly measuring reactor loss, as well as iron loss and copper loss ratios within reactor loss, you can significantly reduce research and development time and identify areas of improvement for reaching even higher efficiency and smaller form factors.

- High iron loss -> Issues with the core likely; focus on improving the structure and materials.
- High copper loss -> Issues with the winding coil likely; focus on improving the winding method or materials.

### How is Reactor Loss Measured?

High frequency current is applied to the reactor. The Power Analyzer then measures the reactor loss, as well as core loss using a detection winding coil that can identify core magnetic flux.

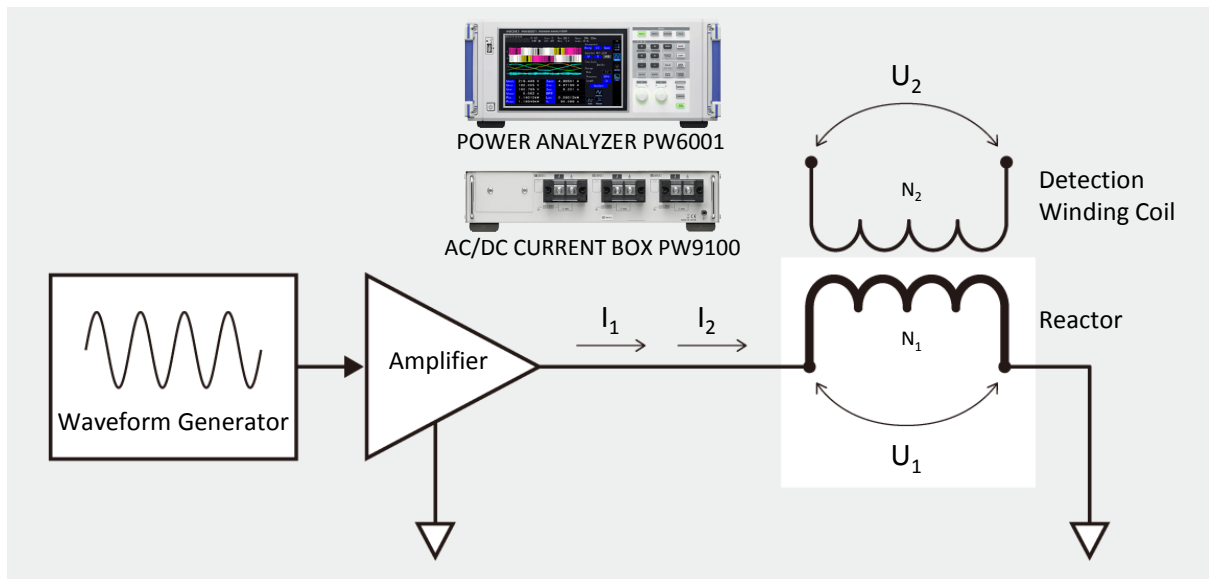

### Measurable Parameters

- Reactor "Total Loss" is equal to power calculated from  $U_1$  and  $I_1$ .
- Reactor "Iron Loss (Core Loss)" is equal to power calculated from  $U_2$  and  $I_2$ . ("Iron Loss" is loss generated from current magnetization of the core magnetic material.)
- "Copper Loss" can be derived from "Total Loss" and "Iron Loss". ("Copper Loss" is loss generated from the resistance component of the winding coil.)
- "Iron Loss Ratio" and "Copper Loss Ratio" can be derived from "Iron Loss" and "Copper Loss."

### Key Benefits of Power Analyzers

Thanks to the wide frequency bandwidth and phase shift correction function, devices that exhibit high frequency and lower power factor power such as reactors and capacitors can be accurately measured. Based on your own defined formulas, compute and display the parameters required for evaluation directly on the power analyzer. With the high speed simultaneous analytical capabilities available on the motor analysis engine, easily verify waveforms, calculated values, harmonics, noise, FFT and other important parameters on the toggle display.

### Formulas

$$\text{Total Loss [W]} = P_1 = U_1 \times I_1 \times \cos\theta_1$$

$$\text{Iron Loss (Core Loss) [W]} = P_2 = U_2 \times I_2 \times \cos\theta_2$$

$$\text{Iron Loss Ratio [\%]} = \text{Iron Loss} / \text{Total Loss} \times 100$$

$$\text{Winding Resistance } [\Omega] = \text{Copper Loss} / (I_1)^2$$

$$\text{Copper Loss [W]} = \text{Total Loss} - \text{Iron Loss} = P_1 - P_2$$

$$\text{Copper Loss Ratio [\%]} = \text{Copper Loss} / \text{Total Loss}$$

### Products used

- POWER ANALYZER PW6001-02 x 1
- AC/DC CURRENT BOX PW9100-03 (50A, DC to 3.5MHz, 3ch) x 1  
or AC/DC CURRENT SENSOR CT6904 (500A, DC to 4MHz, feed-through type) x 2
- ※ Customers need to provide their own waveform generator and amplifier with the appropriate specifications as required.

- Information valid as of July 2018.
- Specifications are subject to change and revision without notice.

Vehicles, Motor / R&D, Testing

## Winding the Secondary Coil (Detection Winding) when Measuring Iron Loss with the 2-Coil Method

- This application note provides guidance on how to wind a detection coil. Learning the methods is extremely valuable for carrying out precise measurement of reactor loss in booster chopper circuits as shown in Fig. 1.
- The key to winding is to improve the coupling coefficient between the primary coil ( $N_1$  (turns)) and the detection coil ( $N_2$  (turns)). Detecting all the magnetic flux generated from the primary coil with the detection coil makes it possible to measure the reactor loss without error generated by the leakage flux.
- The wire diameter of detection coil may be made smaller as no current will be flowing through it.
- The voltage induced across the detection coil depends on the turn ratio. Ensure a sufficient number of winding turns so that enough voltage is induced when measuring it with a Power Analyzer, but bearing in mind that in order to keep the effects of the input impedance of the power analyzer small, the number of turns of the detection coil should not be too high. You can get the best results with  $N_1 = N_2$  in many cases.

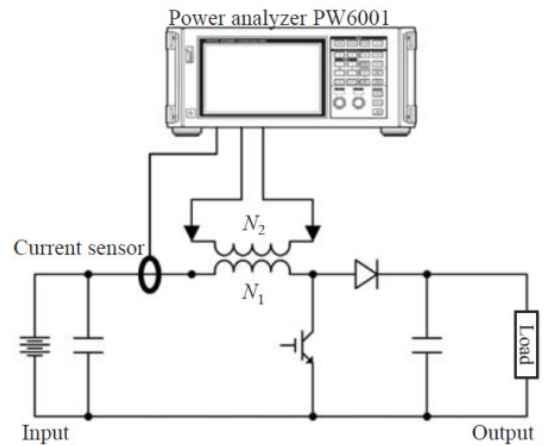

Fig. 1. Reactor loss measurement with 2-coil method

[Definitions]

- 2-coil method  
Method to derive iron loss by measuring the current of the primary coil and the voltage of the detection coil.
- Copper loss and iron loss  
Copper loss = Total loss - Iron loss

### 1. Toroidal core

By winding the primary coil along with the detection coil as illustrated in Fig. 2, the coupling coefficient between primary and detection coils can be maximized.

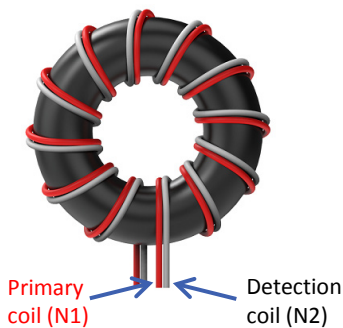

Fig. 2. How to wind primary and detection coils

Practically, the primary coil would be already wound on a core. In that case, wind uniformly the detection coil on the primary coil as shown in Fig. 3.

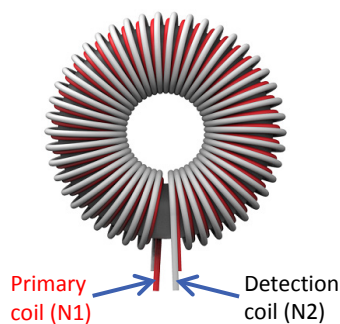

Fig. 3. How to wind detection coil on primary coil

### 2. EI-shaped core

Basically for EI-shaped cores, the same applies as for the toroidal core. By winding the primary coil along with the detection coil as illustrated in Fig. 4, the coupling coefficient between primary and detection coils will be maximized. When the primary is already wound on a core under test, wrap the detection coil evenly over the primary coil.

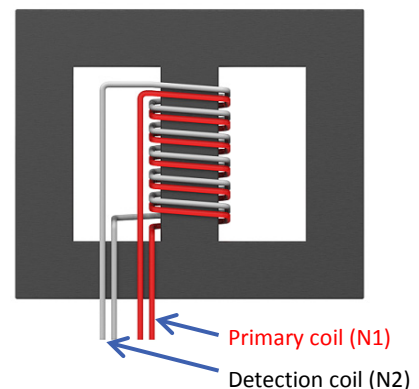

Fig. 4. How to wind detection coil on primary coil

Electric Vehicles/ Energy R&D, Testing

## Impedance Measurement of Reactors While in Operation

Power analyzer measures reactor impedance

### Why Should A Reactor's Impedance Be Measured?

By identifying the impedance of a reactor while it is in operation, you can gain indices that aid in circuit design. Because there is a level dependency in reactor impedance, values measured by an LCR meter differ from the actual value when the reactor is in operation. By using a Power Analyzer to measure impedance while a reactor is in operation, you can capture the true impedance value.

### How is Impedance Measured?

High frequency current is applied to the reactor. The Power Analyzer then measures the reactor voltage, current, and phase difference. Using the measurement results, we can then measure impedance, inductance and resistance components.

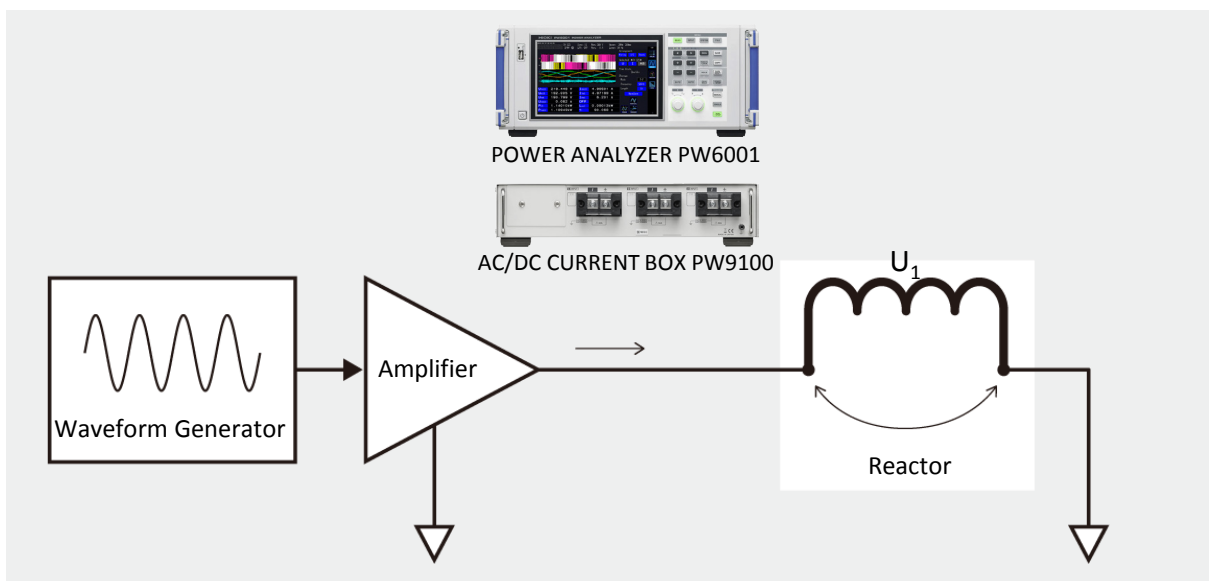

### Measurable Parameters

Reactor Inductance  $Z$  and Phase Difference  $\theta$  can be derived from  $U_1$  and  $I_1$ .

Inductance  $L_s$  and Resistance Component  $R_s$  can be derived from Inductance  $Z$  and Phase Difference  $\theta$ .

### Key Benefits of Power Analyzers

Thanks to the wide frequency bandwidth and phase shift correction function, the amplitude and phase of high frequency voltage and currents on reactors, capacitors, and similar devices can be accurately measured.

Based on the customer's own defined formulas, display the parameters associated with the impedance of circuit elements on the Power Analyzer in real time.

With the X-Y Plot Function, display the correlations between multiple parameters in a frequency characteristics graph or similar tool on the Power Analyzer in real time.

### Formulas

$$\text{Impedance } Z [\Omega] = U_{\text{fnd1}} / I_{\text{fnd1}}$$

$$\text{Reactance } X [\Omega] = Z \times \sin(\theta_{U_1} - \theta_{I_1})$$

$$\text{Inductance } L_s [\text{H}] = X / 2\pi f$$

$$\text{Resistance Component } R_s [\Omega] = Z \times \cos(\theta_{U_1} - \theta_{I_1})$$

### Products used

- POWER ANALYZER PW6001-01 x 1
- AC/DC CURRENT BOX PW9100-03 (50A, DC to 3.5MHz, 3ch) x 1  
or AC/DC CURRENT SENSOR CT6904 (500A, DC to 4MHz, feed-through type)
- ※ Customers need to provide their own waveform generator and amplifier with the appropriate specifications as required.

- Information valid as of July 2018.
- Specifications are subject to change and revision without notice.